

Chance
MERRY - GO - ROUND

MFG: CHANCE RIDES, INC.
NAME: MERRY-GO-ROUND
TYPE: NON-KIDDIE

SPEED: 5 rpm

DIRECTION: Counterclockwise

DURATION:

PASSENGER CAPACITY: 24 adults and 16 children (5520 lbs)

Horses - 1 adult or 1 child (170 lbs) / Chariot - 4 adults or 6 children (680 lbs)

DAILY PRE-OPENING INSPECTION

(This inspection shall include but not to be limited to the following)

1. Fencing around ride.
2. Check condition of horses and chariots, including horse poles and crank hook.
3. Check telescope assembly.
4. Check drive chain tension.
5. Check V-belts.
6. Check that all pins and bolts are in place and secure.
7. Check brakes.
8. Check operating controls.
9. Check for missing "R" keys.
10. Check "U" blocking.
11. Check ceiling to inside scenery for shifting.

OPERATION OF RIDE

The ride can be loaded from all sides simultaneously. When loading an empty ride, it is necessary to maintain a balanced load. (Never operate the ride with an imbalance of more than six adults on any one side.) When loading passengers, make sure that the passengers are properly seated. Passengers on horses must hold onto the horse pole with the seat belt latched and adjusted. Passengers' feet must be on the horse steps. Never operate the ride while anyone is standing inside the fence area.

RIDE OPERATOR'S POSITION AND FUNCTION

Read the service operational manual and be aware of proper operation, maintenance and safety procedures. Inspect the ride before each day of operation. Perform the manufacturer's recommended maintenance procedures. The operator at the control console is responsible for the safety of the passengers as the enter, exit and ride. Instruct passengers that they must not move around while the ride is in motion. Do not allow anyone to walk on the ride platform while the ride is in motion. Passengers on horses must stay seated, holding onto the horse pole, with their feet on the horse steps and the seat belt latched and adjusted. Passengers in chariots must stay seated.

Before starting the ride, make sure there is no one around the ride structure, close to any exposed electrical components or any other area where there is a possibility of personal injury.

The operator must remain in full control of the operating controls at all times during the operation of the ride. The ride and its passengers must be given the full attention of the operator at all times. Never leave the operating controls while the ride is in operation.

Chance
MERRY - GO - ROUND

GENERAL SAFETY PROCEDURES

1. Height requirements: All persons less than 42 inches in height must be accompanied by an adult.
2. Do not allow any passenger on the ride who cannot be properly secured because of passenger size or condition.
3. Never allow a passenger who is visibly ill or under the influence of drugs or alcohol on the ride..
4. Pregnant women or persons who have physical impairments must be advised of potential risks before riding.
5. Never allow two person to ride on one horse.
6. Do not allow anyone to ride side-saddle.
7. Never allow the ride to become overloaded.

EMERGENCY PROCEDURES

In the event of an emergency bring the ride to a complete stop and evacuate the riders as quickly and safely as possible.

In the event of loss of electrical power to the ride during operation, the ride will coast to a stop. If electrical power is not restored, carefully unload passengers.

PROCEDURE FOR AN INCIDENT

1. Call your supervisor.
2. **DO NOT MOVE THE INJURED PERSON.**
3. Assist in crowd control to make way for emergency vehicles.

PROCEDURE FOR PERSONS WITH DISABILITIES

Persons may ride if:

1. They meet the height requirement.
2. They are able to be restrained by the lap bar or seat belt.
3. They can get into the seat by themselves or the assistance of someone with them.

5' x 12'

13 11/32
546 79
379 12
70 66

36', 40' and 45' MERRY-GO-ROUND

(Allan Herschell-Built Rides)

OPERATION MANUAL AND
PARTS CATALOG

Manual Number 24327204

Chance Manufacturing Company, Inc. has
ceased operations as a corporation. The
information herein is supplied by
Chance Rides, Inc.

Chance Rides, Inc. SPECIFICALLY
DISCLAIMS ANY LIABILITY
for losses associated with rides produced by
Chance Manufacturing Company, Inc.



CHANCE
MANUFACTURING CO., INC.

Date: 3-7-72

America's Largest Manufacturer of Amusement Rides

Service Information

Effective Serial Numbers: ALLAN HERSCHELL BUILT RIDES

Ride: 36', 40', & 45' MERRY-GO-ROUNDS Subject: ERECTION AND MAINTENANCE

Reference:
Print MG-268 General Arrangement
Print MG-100-PA Parts Numbers and
Lubrication
Print MG-320 Electric Circuit
Electric Consumption Sheet
Packing List

ERECTION INSTRUCTIONS FOR 36', 40', and 45' MERRY-GO-ROUNDS

1. Refer to General Arrangement Drawing MG-268. Lay the foundation in place, which consists of two steel cross members and are commonly called Mud Sills. (MG-229) These Mud Sills must be placed on solid level ground, concrete piers or concrete slab. It is necessary to position the mud sills so that the Drive Unit and winch positions are convenient for erection since this relationship cannot be changed later. Use the carpenters bubble level to make certain that the mud sills are level in all directions. Use thin wood or metal shims under the ends of the mud sills as necessary to obtain a perfect level. If shims are used under ends of mud sills, it is important that the mud sill center under the center pole also be shimmed to assure a tight ground contact. Position the drive base to top of mud sills and secure with taper pins.
2. INSTALLATION AND ASSEMBLY OF CENTER POLE (Dwg. MG-268)
 - (a) Place wooden folding buck support across end of mud sill so the center pole base hinge casting bracket points to support buck. Using several men, position the center pole MG-136-2 on the support buck as per above drawing. If center pole hinge bracket is not bolted in place (export models only) perform this operation making certain that the rounded edges of hinge face bottom of pole. Mate the center pole hinge bracket with hinge casting on center of mud sills, insert hinge bolt and lock in place with nut. When the Merry-Go-Round is taken down, make certain that center pole hinge bolt is loose before lowering the center pole.
 - (b) Slide Center Pole Brace Hub (MG-225) over the top of the center pole so that the bearing surface is facing the top of the pole. Align brace hub with drilled holes in center pole by mating stamped arrows on center pole

Factory and General Office, 4219 Irving, P.O. Box 12328 Wichita, Kansas 67277

Area Code (316) 942-7411

Sales Office:

1103 Ross Ave., Dallas, Texas 75202

Area Code (214) 742-3802

ERECTION OF CENTER POLE ASSEMBLY (Dwg. MG-268) (continued)

4. Nail together the staging ladders and place plank in position at right angles to center pole to make a scaffold for installation of the sweeps, the hanging rods and positioning of crankshafts. The scaffold can remain in one position and the entire moving assembly rotated by hand around to this one location. Hook one long and one short sweep guy rod (MG-26 -1 and 2) into opening #1 of the spider at the top of the center pole. Insert the #1 sweep arm MG-248 into the mating numbered slot of the sweep hub. Attach long and short guy rods to proper fittings at the top of the sweep arm. Repeat this operation in sequence for all sweep arms. NOTE: (On the 45' Merry-Go-Round, the sweep arms which carry the electric wiring must be placed opposite each other).
5. Assemble the inside and outside sweep arm cross rails (MG-226-142) between sweep arms with safety pins. Note that the cross rails without bearings are placed between sweep arms #1 and #2, #7 and #8 since the chariots are used below these locations.
6. Install crankshafts (MG-279-1) in position, alternating large and small bevel gears with small gears to center of bevel gear. The crankshaft throws must be 180 degrees apart on alternate shafts to give proper action to the jumping horses. When a fixed scaffold is used, the Merry-Go-Round is rotated by hand to bring the work into proper position over the scaffold. The crankshaft throws can each be placed in an upright position and they will properly position themselves. Note that no crankshafts are used between sweeps #1, #2, #7 and #8 because of the chariot positions. The crankshaft tee bearings are inserted over the vertical studs on the sweep hub and the set screws tightened to lock in place.
7. The outside numbered scenery panels are called cornices (MG-161), and are positioned at ends of the sweep arms in sequence to mate with sweep arm numbers. Move the wooden scaffold to outside ends of sweep arms as they are removed from the packing crate. The cornices are locked in place with large flat metal keys. The cornice light shields (MG-171) are hung at the cornice joints and secured with thumb screws at the bottom edge of the shields. Notice that each cornice is numbered and must be mated in proper sequence to sweep arms while light shields are interchangeable.
8. The two halves of the canvas tent top are spread over the top of the sweep guy rods with the smooth side of the canvas facing the top. Care must be taken so as not to tear or damage the canvas. The draw lines for block and tackle are allowed to hang alongside the center pole and metal split ring of tent top assembled around draw lines. With the block and tackle attached to the split ring at the top of the canvas, individually pull each half of the tent top into position. Lace the two halves together and snap outside edges to cornice. Add vertical metal quarter poles to underside of canvas to provide additional support and give characteristic shape to tent. The draw lines of tent top block and tackle may be secured to metal eyes on #2 and #8 sweeps.
9. Hook Platform Hanger Rods (MG-195) to eyes welded to underside of sweep arms. Place metal platform support channels in place over the bottom nut on the end of the platform support rods. The platform channels have one end beveled, and this beveled end should be facing the outside of the Merry-Go-Round.

ERECTION OF CENTER POLE ASSEMBLY (Dwg. 268) (continued)

14. Double check all pins, safety pins, set screws and nuts to make certain that they are secure and tight.
15. The canvas sidewalls are secured to the eyelets on the sweep arms and then rolled to the top and secured to the sweep arms with the webbing straps provided.
16. Carefully double check all fittings, pins, safety pins, nuts, cotter keys and electrical connections for security. Lubricate the entire Merry-Go-Round per instructions before starting the motor.
17. Clear the Merry-Go-Round of all tools, light cords, crates, etc. before testing the unit.

LUBRICATION

If a regular program of lubrication is followed, using recommended oil and grease, you will be rewarded with many, many years of trouble-free operation and few maintenance problems. Before the first operation of the Merry-Go-Round, lubricate the entire machine, with the exception of the gear reducer, using Socony PD-1020-A or the Shell Retinax "A" which is shipped in the tool box. When the Merry-Go-Round is located near salt water, use Fiske Bros. Lubriplate #630-AA. If a gasoline engine is used for power, a good grade of SAE #20 automobile oil is used in the crankcase.

- (a) Fluid Drive Unit - At the factory, the fluid drive clutch has been given the correct amount of premium grade SAE #10 for proper operation. Change the oil at start of each season and check monthly. A slippage of 85 RPM of motor and RPM of fluid clutch drive is standard. Excess slippage indicates the need for additional oil. When filling or adding oil to the clutch, the mark on the housing rim at the 2-1/2" position is placed top dead center. This will position the filler plug opening 36 degrees off center so that oil added until it starts to run out of the opening will properly fill the clutch. Use SAE #10-W oil. Gasket compound is recommended for plug threads to eliminate leakage. The fluid clutch bearings are lubricated for life and require no attention.
- (b) Vertical Drive Shaft Worm Reducer Link Belt V-350 on 36' Merry-Go-Round. Link Belt WV-500 on 45' Merry-Go-Round.
 1. Follow instructions on the name plate using 600-W in warm weather and a combination of 1/2 SAE #40 and 1/2 of 600-W in cold weather. Maintain the proper level.
 2. Drain and refill after 150 hours of operation.

MAINTENANCE SUGGESTIONS (continued)CAUTION:

Belt adjustment must be made by moving the engine or the motor--never by moving the fixed position of the gear reducer.

- (b) The life of the entire drive unit and chain will be increased if the chain is removed once a year and reinstalled in an upside down position. A removable chain link is installed for this purpose.
- (c) Remove slack from the drive chain when it becomes more than 1/8" to 1/4" by using the set screw and locknut on the banjo. It is important that the chain is not too tight or excessive wear results.
- (d) The automatic electric brake brings the ride to a gentle but positive stop with either the gasoline or electric motor. On electric drives, the brake is automatically applied when the electric timer switch stops the flow of current to the motor and brake.

On gasoline engine drives, the brake is controlled from a manual toggle switch near the timer. A new brake usually requires several adjustments until the brake shoe surfaces are properly seated. Adjustments for torque, lining wear and equalizing brake shoe clearance are to be made according to the instructions on the nameplate of the brake assembly. A set screw and lock nut mounted on top of the solenoid frame provides adjustment for equalizing clearance between the two brake shoes to prevent dragging when the brake is released.

ALLAN HERSCHELL CO., INC.

REPAIR PARTS LIST

CARROUSELS

NORTH TONAWANDA N.Y. 14120

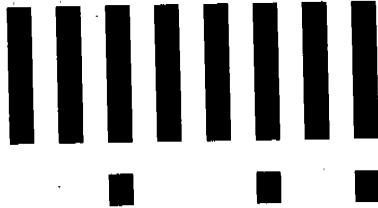

LTR



Duplex mode

36 FOOT AND 50 FOOT CARROUSELS

Field inspection and test guide

Contents

Introduction	2
Ride description	2
Operation	4
Operating controls	4
Operating the ride (test cycle)	6
General inspection and testing	7
Testing	7
Field performance testing of amusement rides	7
Non-destructive testing	9
Fasteners	10
Capscrews	10
Pins	13
Inspection	15
Joint inspection	15
Cable inspection	16
Leveling and blocking (portable models)	18
General safety guidelines	20
Horse and pole inspection	21
Sweep inspection	24
Electrical and lighting inspection	25
Trailer or park base inspection	25
Drive inspection	26
Platform and fence inspection	28
Bibliography	30

CHANCE RIDES, INC.

4219 Irving
P.O. Box 12328
Wichita, KS 67277-2328

phone (316) 942-7411
toll free 1-800-242-6231
fax (316) 942-7416



Introduction

Proper maintenance is essential to the safe operation of this ride. The tests and inspection points outlined in this field guide are not intended to replace the recommended maintenance schedule. This guide does not contain maintenance and repair procedures and should only be used as a ride inspection and test guide.

When repairs are necessary, use only those components authorized, specified or provided by the manufacturer. If any alterations, modifications and/or additions, installations of unauthorized components are made to the original design without the manufacturer's explicit written consent or without direct supervision by a manufacturer's representative, CHANCE RIDES, INC. makes no claims as to the integrity of the altered or modified ride (product).

Information in this field inspection and testing guide applies only to products manufactured by CHANCE RIDES INC. built after January 1, 1986 (36 Foot Carrousel serial number MGR-07186 and on / 50 Foot Carrousel serial number 389-01086 and on).

CHANCE RIDES INC., reserves the right to make improvements in design or changes in specifications at any time without incurring any obligation to such changes.

Ride description

The **36 Foot** and **50 Foot Carrouseles** are mounted on either a trailer or a stationary base. The stationary base should be anchored to the ground for permanent installation. One or more auxiliary trailers provide additional racking provisions for portability. The ride rotates in a counter-clockwise direction by either an electro-hydraulic drive with integral hydraulic braking, or an electric drive with an electro-mechanical brake.



Operation

Operating controls

NOTE: Some rides are equipped with a fixed control panel on the hydraulic pallet. Control functions are similar.

1. Pump switch - This switch controls the hydraulic pump. Turn the switch off before leaving the control console. Do not stop the ride by turning off the pump.

2. Start switch - Push this button to start the timed ride cycle. At the end of the cycle the ride will brake to a stop.

3. Emergency stop switch - This switch interrupts the timed ride cycle. The ride will brake to a stop.

4. Lights switch - This switch controls the decorative lighting on the ride.

5. Jog button (if equipped) - Push this switch to rotate the ride to any position.

6. Operator presence switch (if equipped) - This foot switch must be depressed to operate the start or jog switches. If the switch is released, the ride cycle is interrupted and the ride will brake to a stop.

7. Main power switch (if equipped) - This switch turns off the main power circuit breaker.

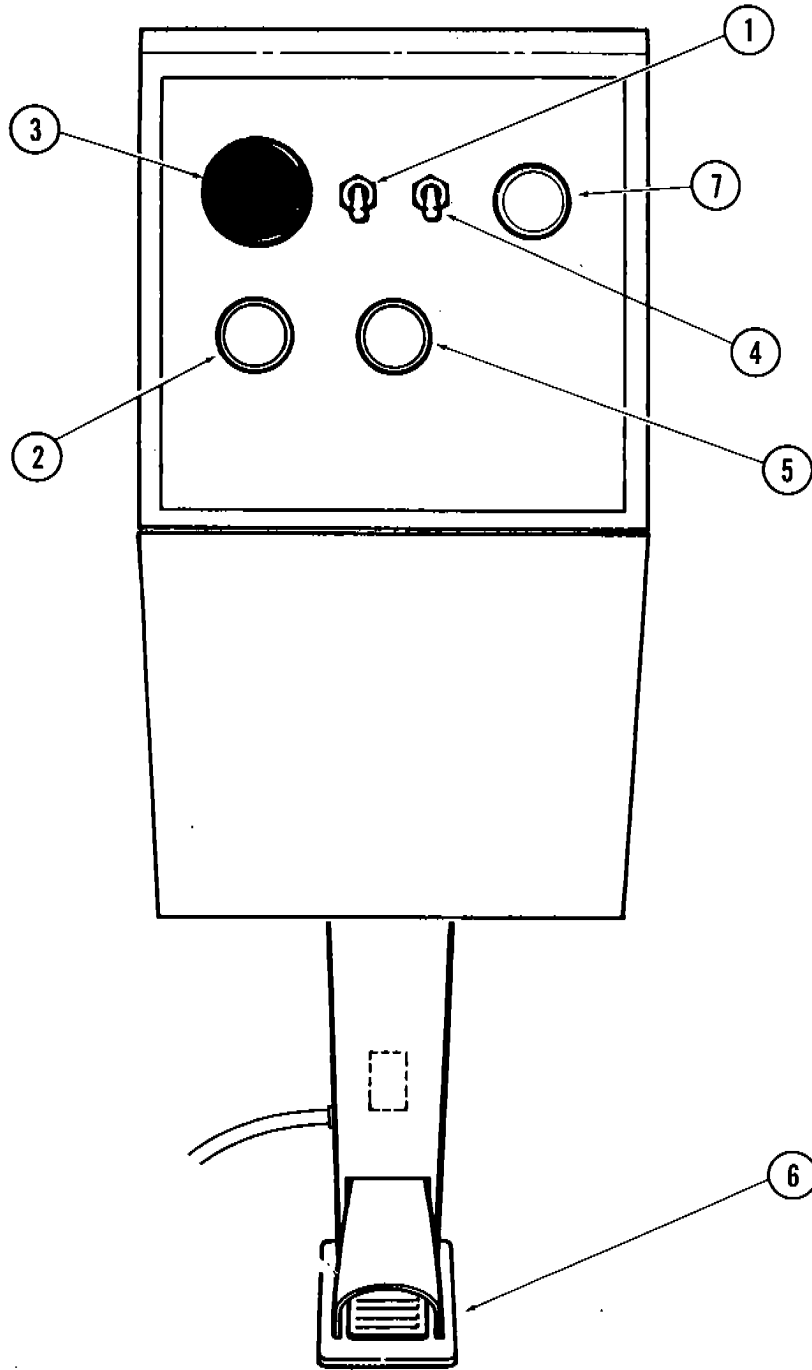

Operating controls

- 1. Pump switch
- 2. Start switch
- 3. Stop switch
- 4. Lights switch
- 5. Jog button (if equipped)
- 6. Operator presence switch (if equipped)
- 7. Main power switch (if equipped)

Operating the ride (test cycle)

The operating procedure is provided in the *Carrousel Operation Manual and Parts Catalog*. Make sure that a copy of the manual is readily available.

Test the operation of all controls. Throughout the ride cycle, check for correct speed and proper brake operation. Check the overall performance of the ride based on previous operating performances of the individual ride.

General inspection and testing

Testing

Field performance testing of amusement rides¹

The following specifications conform with ASTM F846 standard guide for *Testing Performance Of Amusement Rides And Devices*, in effect on date of ride manufacture.

Erection or installation testing

Each erection or installation of a ride shall be given an inspection prior to carrying passengers that shall include but not be limited to the following:

- a. Determine that ride has been erected according to the set-up procedures in the operations manual.
- b. Inspect field inspection points listed in the *Field Inspection Guide*.
- c. Visual check of all passenger carrying devices including restraint devices and latches, and the pins and capscrews securing them.
- d. Visual inspection of entrances, exits, stairways and ramps and devices securing them.
- e. Test of all communications equipment necessary for operation of the ride or device.
- f. Operate the ride to determine that direction of travel conforms to the information plate, ride manual field inspection guide of specification sheet.
- g. Operate the ride for a minimum of three ride cycles to determine that the ride speed does not exceed the speed specified in the information plate, ride manual field inspection guide of specification sheet.

Daily pre-opening inspection

This inspection shall include a daily inspection of all items as specified in the previous item (erection or installation testing).

Documented field performance and operational testing

Documentation and certification shall be performed by a person who by demonstrated education and field experience is knowledgeable with construction, erection, operation, maintenance and repair of amusement rides.

Operational load testing

Any operational test including load testing performed on a ride shall be completely non-destructive in nature. Overload testing exceeding the rated limits listed on the information plate, operation manual, field inspection guide or specification sheet shall be deemed inappropriate. Where maximum total passenger weight is not readily available, passenger capacity multiplied by 170 pounds per adult and/or 90 pounds per child may be used.

Non destructive testing with inert loads can be accomplished only with special care as to placement of the load so that it is centered both vertically and horizontally as would be the load of the passenger it replaces. Extra seat reinforcement must be used to offset any load concentration created. Such tests shall be documented and certified as non-destructive by the person making the test and the agency requiring it. Results of all load tests shall be communicated to the factory upon completion by the certifying agency.

Conducting a non-destructive operational load test assures the testing agency only that it will carry a given load in a given way at a given moment and in no way assures future safety of the ride.

Conducting a destructive load or overload test also assures the testing agency that it will carry a given load in a given way at a given moment and in no way assures future safety of the ride. However, it also introduces the probability of inflicting serious irreparable damage to the ride that may or may not be apparent at the time of the test.

CHANCE RIDES, INC. considers inert load testing of any nature appropriate only for situations requiring experimental development of stress-strain testing during prototype development. A certificate of load test on the prototype and certification that each production ride met the design criteria when it was manufactured is available from the factory upon request.

Non-destructive testing²

- REFERENCE** 1. *ASTM-F24 Standard On
STANDARD Amusement Rides And Devices*
- a. *F846-86 Testing Performance Of
Amusement Rides*
 - b. *F853-86 Maintenance Procedures
For Amusement Rides And Devices*
 - c. *F893-87 Inspection Of Amusement
Rides And Devices*

CHANCE RIDES, INC., at the time of design and manufacture, determines by calculations and testing of a prototype amusement ride the appropriateness for use, of not only the parts, but the entire system of a newly designed ride. These calculations and tests are utilized to, as feasibly as possible, determine the requirements for expected design life of major components. Based on this design criteria, CHANCE RIDES, INC. does not identify critical components on amusement rides to be singled out for non-destructive testing.

If through field experience, there is an indication that a structural or mechanical problem may develop on rides currently operating, CHANCE RIDES, INC. will notify owners by bulletin of the recommended procedures to inspect and correct the possible problem. Any possible defect which could affect the continued safe or proper operation of the ride should be reported immediately to the manufacturer by the owner/operator. This information is necessary so that a determination can be made for either the repair or replacement of the possible defective parts.

Field repairs should not be undertaken without the approval and proper instructions from the manufacturer and should be performed by qualified personnel. These persons should have a complete understanding of both the component's function and the manufacturer's instructions.

It is the responsibility of the individual inspector to thoroughly inspect the ride as he deems necessary based on his knowledge and field experience and manufacturer's recommendations. If the inspector finds an area or component that could be a problem, structural or otherwise, the factory should then be notified. It is then the responsibility of the inspector to ensure that the manufacturer's recommendations for repair,

replacement or otherwise have been completed and are in compliance with the required specifications.

Load testing is a destructive form of testing and is not recommended by the manufacturer, as per previous topic "Field performance testing of amusement rides."

Fasteners

Capscrews

Capscrews used by CHANCE RIDES, INC. are classified as functional load-carrying capscrews if:

- They are used as tension members in the erection or operation of the ride

and/or

- They are required to resist shear through friction-type connections in the erection or operation of a ride.

Capscrews are selected with consideration to grade, size and quantity, using joint capacities based on tightness torques of 60% rated yield and group joint efficiencies of 62.5%

Torque requirements⁶

Capscrews must be tightened to the torque values listed in the torque chart. These values were selected to produce a tightening torque range of 60% to 70% of proof load, when tightened with a hardened washer under the nut or capscrew head (whichever is accessible for tightening). When the capscrew is tightened from the head end, apply anti-seize lubricant to the shank end of the capscrew. When the threads are lubricated, use 10% less torque to tighten the capscrew.

DO NOT TIGHTEN CAPSCREWS OVER THE RECOMMENDED TORQUE. This can damage the capscrew, due to variances in coefficients of friction and torque wrench accuracy.

Always use a torque wrench. It is impossible to accurately measure the tightness of a capscrew by other methods. Torque wrenches must be checked for accuracy twice each operating season.

Size Diameter - Threads/inch	Foot pound torque range (see notes 1 and 2) with locknut and hardened washer	
	SAE J429 Grade 5 ASTM A325	SAE J429 Grade 8 ASTM A490
1/4 - 20	5-6	7-8
1/4 - 28	6-7	8-10
5/16 - 18	11-13	15-18
5/16 - 24	12-15	17-21
3/8 - 16	19-24	27-33
3/8 - 24	22-27	31-38
7/16 - 14	30-35	45-55
7/16 - 20	35-40	50-60
1/2 - 13	50-60	65-80
1/2 - 20	55-65	75-90
5/8 - 11	95-115	130-160
5/8 - 18	105-130	150-180
3/4 - 10	165-200	235-285
3/4 - 16	185-225	260-320
7/8 - 9	270-325	380-460
7/8 - 14	295-360	415-505
1 - 8	400-490	565-690
1 - 12	440-535	620-755
1 1/8 - 7	495-600	800-975
1 1/8 - 12	555-675	900-1095
1 1/4 - 7	700-850	1135-1380
1 1/4 - 12	775-940	1255-1525
1 1/2 - 6	1215-1480	1975-2395
1 1/2 - 12	1370-1660	2220-2700

Torque chart

Torques for functional load carrying cold finished hex head capscrews with dry rolled threads, used with locknuts (see note 3), and tightened with an ASTM A325 hardened washer under the capscrew or locknut head (whichever is accessible for tightening).

This torque range will develop 60% to 70% of proof load.

*Refer to **Replacement of capscrews and locknuts** for conditions requiring replacement*

NOTES

- 1. Use anti-seize lubricant on capscrew shank when tightened from head end.*
- 2. Use 10% less torque when anti-seize or other lubricant is used on threads.*
- 3. Use same torque range for holes tapped in steel.*







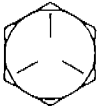
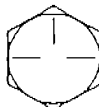
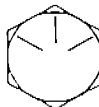

Capscrew grades

CHANCE RIDES, INC. uses only grade 5 or better capscrews and grade 8 locknuts, with A325 hardened washers for functional loads. The *Grade markings chart* shows the capscrew markings to be found on CHANCE rides. The manufacturer's identification symbols must be present on all functional load carrying capscrews.

CHANCE RIDES, INC. requires the use of cold-formed hex head capscrews with rolled threads. Hex bolts and hot formed hex head capscrews are not recommended because they may have machined threads and can have die seams along the shank.

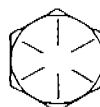
NEVER REPLACE CAPSCREWS OR NUTS WITH PARTS OF A LESSER GRADE, OR DIFFERENT LENGTHS THAN THOSE SHOWN IN THE CHANCE PARTS CATALOG.

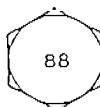
Grade markings for functional load carrying capscrews
 Manufacturer's identification symbols must be present on all capscrews

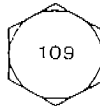
Correct markings	Examples of unacceptable markings	
<p>SAE J429 Grade 5 Medium carbon 81,000 yield</p> 	<p>Grade 5.1 Low carbon</p> 	<p>Grade 5.2 Low carbon martensitic</p> 
<p>ASTM A325 Type 1 Medium carbon Longer shank and shorter thread length than Grade 5 81,000 yield</p>  <p>ASTM A325 Type 3 Corrosion resisting Longer shank and shorter thread length than Grade 5 81,00 yield</p> 	<p>ASTM A325 Type 2 Low carbon martensitic</p> 	
<p>SAE J429 Grade 8 Medium carbon 130,00 yield</p> 	<p>ISO R898 Class 8.8</p> 	<p>Class 8.8 Medium carbon 92,000 yield</p> 
<p>ASTM A490 Alloy steel Longer shank and shorter thread length than Grade 8 130,00 yield</p> 	<p>ISO R898 Class 10.9</p> 	<p>Class 10.9 Alloy steel 130,000 yield</p> 

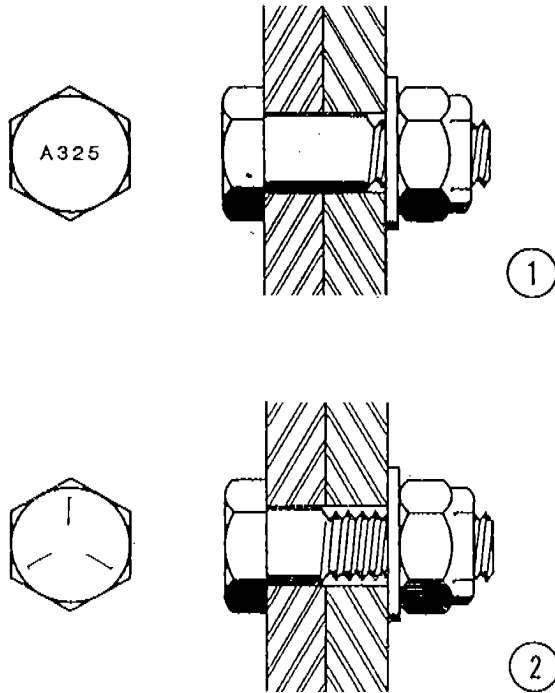

Capscrew comparison
 1. ASTM A325 Capscrew
 Longer shank
 shorter threads
 2. Grade 5 capscrew
 Shorter shank
 longer threads

Replacement of capscrews and locknuts

When permanently installed capscrews and locknuts are disassembled for repair or adjustment, they must be replaced if they have been in service over five (5) years, or corrosion, or other damage requires over-torquing for removal. If a torque wrench is not used to measure excessive removal torques, the capscrews and locknuts must be replaced.

Capscrews and locknuts which are frequently disassembled for portability must be replaced each operating season. If the capscrews and locknuts become damaged, corroded or require excessive torque for removal, they must be replaced. If a torque wrench is not used to measure excessive removal torques, the capscrews and locknuts must be replaced.

Pins³

Tapered pins used on amusement rides are subject to deterioration due to improper use and wear. CHANCE RIDES, INC. specifies certain pins for certain applications on

amusement rides. These pins have been developed over a period of years, taking into account size, design, material and hardness characteristics.

Use only the pins specified by CHANCE RIDES, INC. These pins are identified as shown in the following illustration. Always use the correct hairpin.

Pin identification

1. Date of manufacture
2. Rounded edges

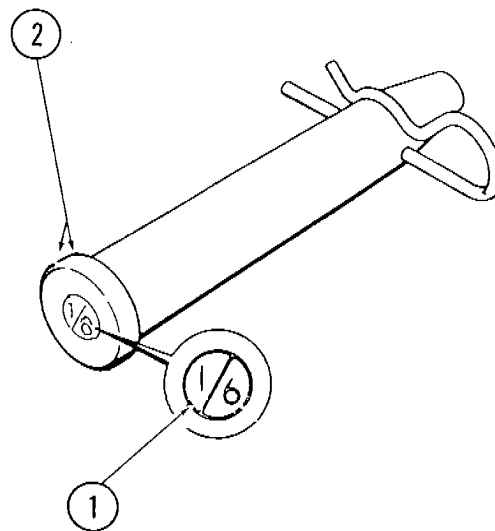

Use care when installing and removing tapered pins. Since these pins are hardened (as are hammers and punches) care must be taken to strike the pin straight on. Striking a pin at an angle can cause the pin to chip, resulting in personal injury. For this reason APPROVED SAFETY GLASSES OR GOGGLES MUST BE WORN AT ALL TIMES when tapered pins are being installed or removed. If a tapered pin is chipped, bent, or "mushroomed" on either end, discard it and replace it with a new pin.

Pin keepers

All keepers (R-keys, hair pins, lynch pins, etc.) must be inspected for wear. If a keeper is bent out of shape or "sprung", it must be replaced.

Hairpins are expendable parts. After repeated use, they become worn and "sprung" as shown.

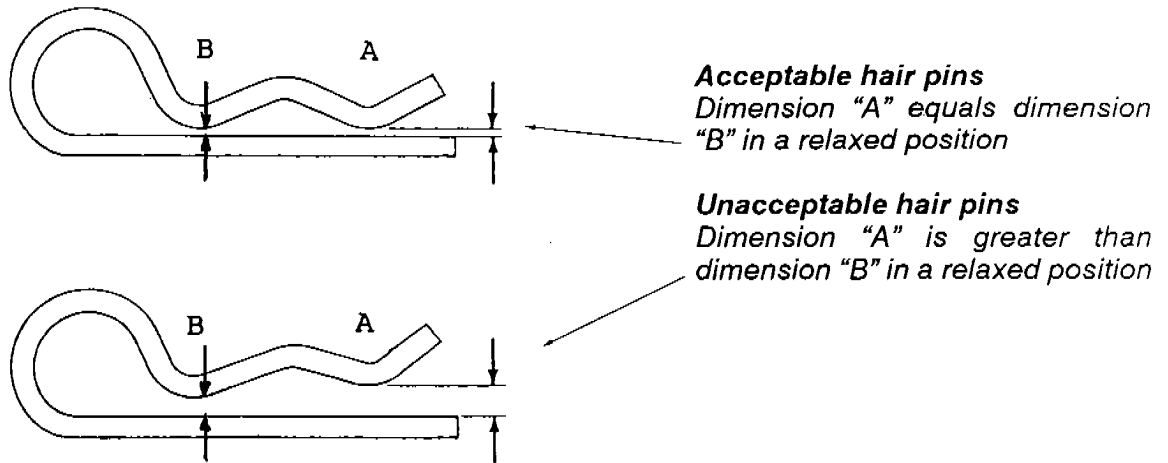

NEVER ATTEMPT TO BEND A HAIR PIN BACK INTO SHAPE.
REPLACE IT WITH A NEW PART.

The correct installation of a hairpin is shown. Incorrectly installed hairpins are more likely to fail, and will distort after only a few uses.

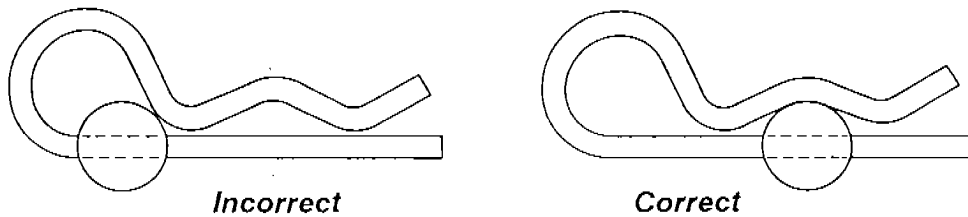

CHANCE RIDES, INC. recognizes and recommends the safety procedures specified in *ASTM Standards F770 Operation Procedures for Amusement Rides and Devices* and *F853 Maintenance Procedures for Amusement Rides and Devices*.

Inspection

Joint inspection

Some joints will appear to wear rapidly on new rides. This is usually a result of the holes not aligning in the mating parts. When this condition occurs it results in "point contact". A joint with this condition will generally wear rapidly until the load is distributed evenly over the fastener and the parts.

If in doubt about the condition of a bolt, pin or hole on a new ride consult CHANCE RIDES, INC., and replace as required.

1. Inspect stationary joints for "egg-shaped" wear and loose pins.

1. Stationary joint wear
2. Stationary joint-misaligned holes resulting in point contact

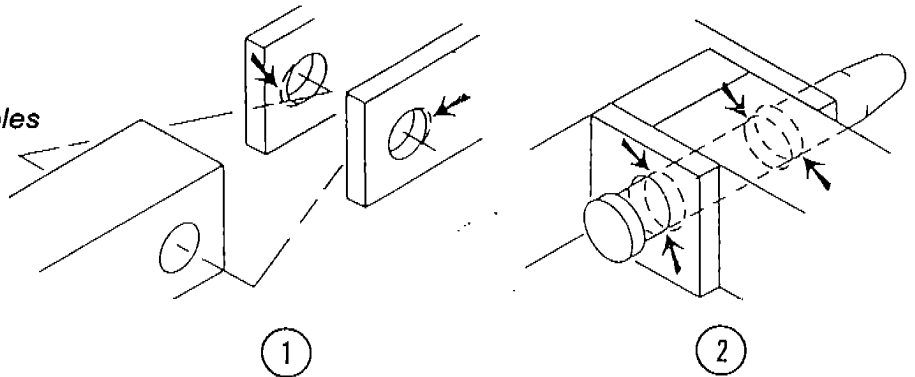

2. Inspect moving joints for wear and lubrication.
3. Inspect welded structural joints for cracking or fatiguing.
4. Inspect bolted structural joints for cracking, fatiguing and proper bolt tightness.
5. Inspect pins and keepers on all pin joints for wear and proper installation.
6. Inspect all pins for proper CHANCE identification marks.

Cable inspection⁵

Replace cables if any of the following conditions exist. If more than one cable is used, cables must be replaced as a set.

1. Severe corrosion
 - a. Rust appearing to stem from interior of cable.
 - b. Cable appears clean but previous corrosion is evident from pitted condition in wires.
2. Severe stretching occurring in a short section of cable, indicated by a marked reduction in the diameter of the cable.
3. Severe physical damage such as kinking, crushing or "bird caging".



Kinking



Crushing



Bird caging

- 4. One strand being 75% broken through.
- 5. A number of wires, equal to the number in a strand, broken in the length of one rope lay.

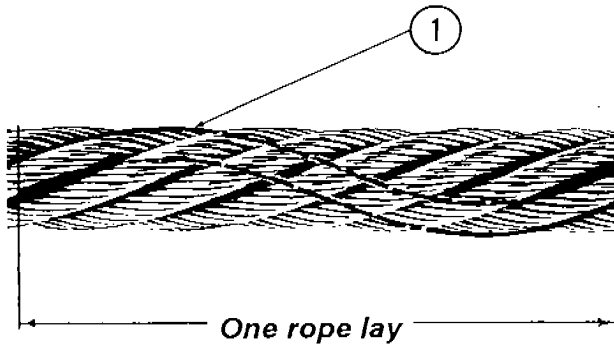

"Lay" as a unit of measure

1. One strand

Leveling and blocking (portable models)

1. Inspect leveling and blocking at each set up and at the start of each day (rides erected in soft locations require more frequent inspection).
2. Inspect for proper cross blocking or crib blocking. Cross blocking distributes weight evenly.

Always cross block
Cross blocking distributes weight evenly.

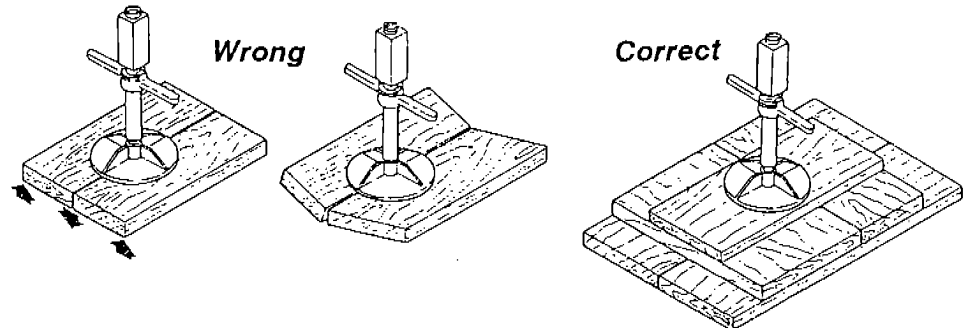

To avoid crushing under load "crib" blocking should be spaced no more than 1/4" for drainage.

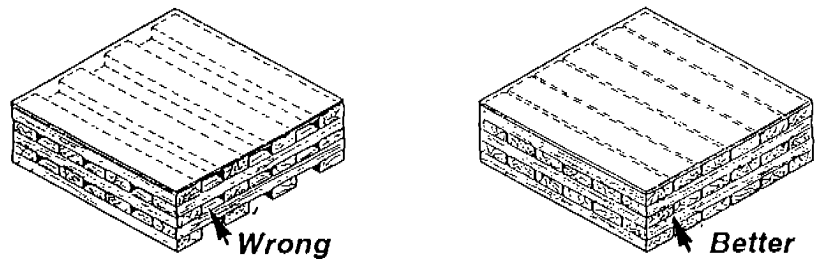

"Crib" blocking
Large voids can let blocking crush under load. 1/4" spaces allow adequate drainage.

3. Inspect blocking for proper contact with ground.

4. Level ground under blocking by digging where possible, instead of filling. Fill dirt will be soft and allow settling.

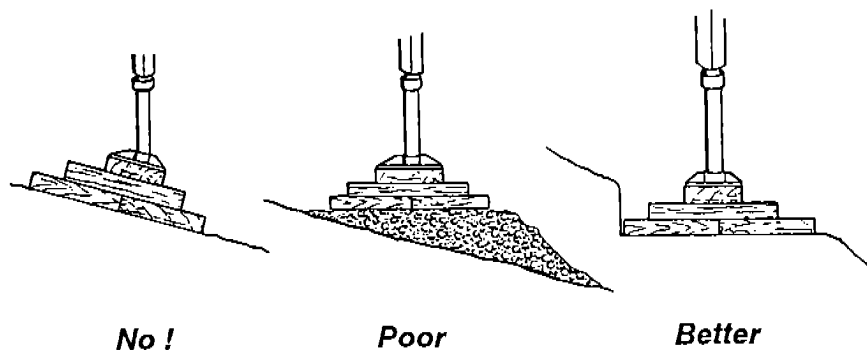

Blocking on a slope
 Level the ground beneath blocking by digging where possible. Don't fill, the fill dirt will be soft allowing the ride to tilt.

5. Inspect hydraulic leveling jacks for leaks at every set-up. The hydraulic jacks are for leveling purposes only. After the ride is leveled and all locking rings have been tightened, open the needle valves and the hand pump valve to relieve hydraulic pressure on the leveling jacks.

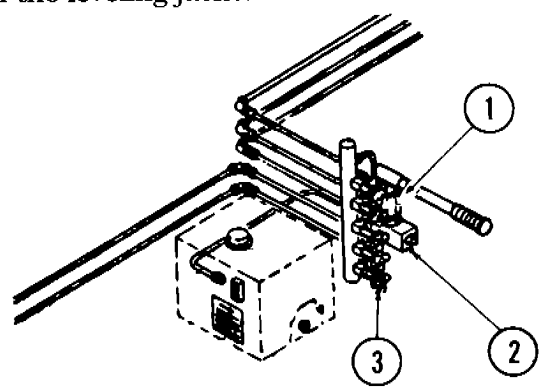

Open shut off valve to release pressure.

- 1. Hand pump
- 2. Hand pump valve
- 3. Needle valve

6. Check the lock rings on all screw jacks for tightness.

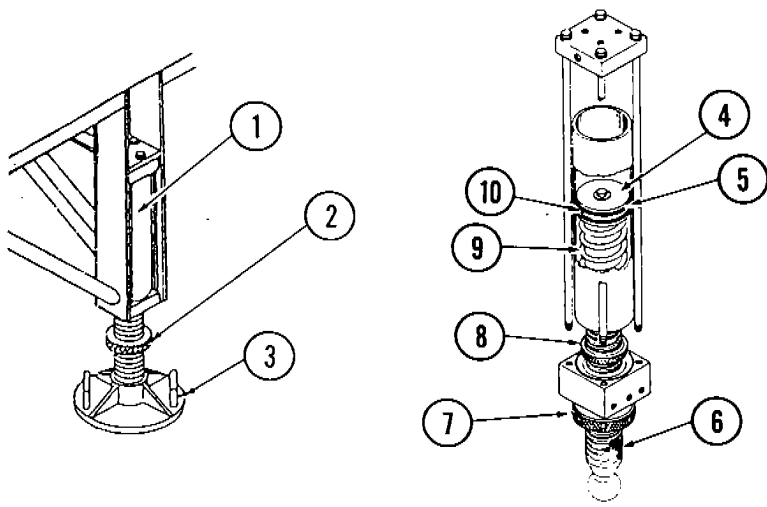

- 1. Leveling cylinder
- 2. Locking ring
- 3. Base
- 4. Piston
- 5. Block vee packing
- 6. Ram
- 7. Lock nut
- 8. Nut
- 9. Ram spring
- 10. Back up washer

General safety guidelines

The following is a list of general safety rules to which everyone should adhere.

1. All work must be performed by competent, qualified mechanics, capable of understanding the function of the parts and their proper installation.
2. Inspect the ride before each day of operation to determine that no portion of the ride is damaged, missing or worn in such a manner that unsafe conditions can develop.
3. Perform the manufacturer's recommended maintenance procedures at the intervals and in the manner specified in the operation and maintenance manual.
4. Study each job carefully to determine all hazards so that necessary safety precautions can be taken.
5. Examine safety devices (tools, ladders, etc.) before they are used to make sure they are in good condition. Ladders must be clean and unpainted.
6. Use the proper tool or equipment for each job. All hand electric power tools must be properly grounded.
7. Wear close fitting, comfortable clothing when working on or near moving parts or live electrical circuits. Avoid finger rings, jewelry or other articles which can be caught in moving parts or come in contact with electrical circuits.
8. Protect your eyes by wearing approved safety glasses or goggles.
9. Wear a hard hat at all times. When working in elevated areas, use a safety belt.
10. Where work performed is hazardous, never work alone.
11. If guards are removed from equipment, make sure they are replaced before leaving the job.
12. Clean up after each job, disposing of surplus materials.
13. Keep a record of parts replaced and the date of replacement. Inform the manufacturer of any replacement requirements which are frequent or cause unsafe conditions.

14. Make modifications and additions only as outlined in manufacturer's service and safety bulletins.

Horse and pole inspection

1. Inspect the horse hanger hooks. Measure the distance between the hooks as shown. The dimension must be within the specified limits*.

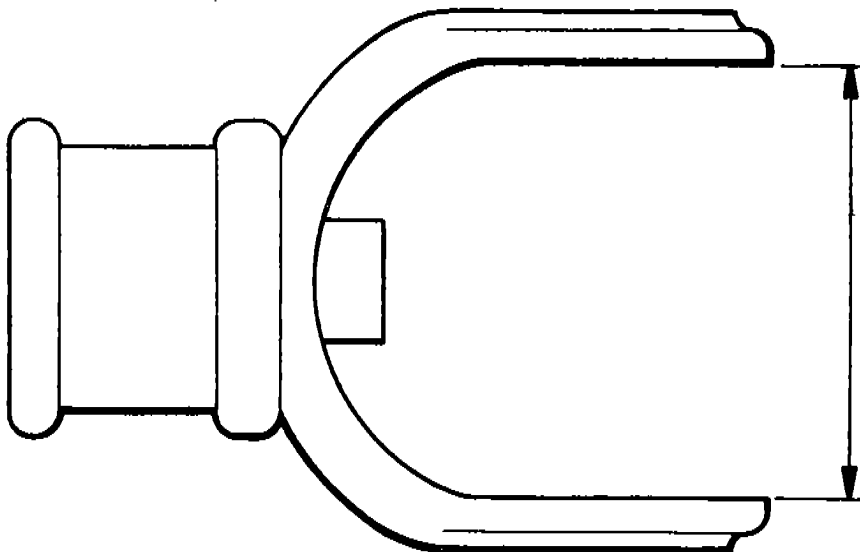

Horse hanger hook

3 3/8" maximum (36' carousel)

4 1/8" maximum (50' carousel)

2. With the hook installed, inspect for excessive wear on the top of the horse hanger bearing ears. Check the clearance between the safety stops. This gap must not exceed $3/16$ "⁴.

3. Make sure all horse hanger pipes are securely riveted to the horse pipe⁴. Loose rivets are not acceptable.

4. Inspect the chamfers on the bottom of each horse pipe and the top of each telescope pipe. All parts must have these chamfers⁴.

5. Inspect the lower casting on each telescope and the upper castin on each floor lock. Look for wear or damage which can prevent secure locking of the telescope into the floor. Parts must require deliberate effort to lock or unlock.

6. Inspect horses, stirrups and reins (if equipped) for worn, broken or missing parts.

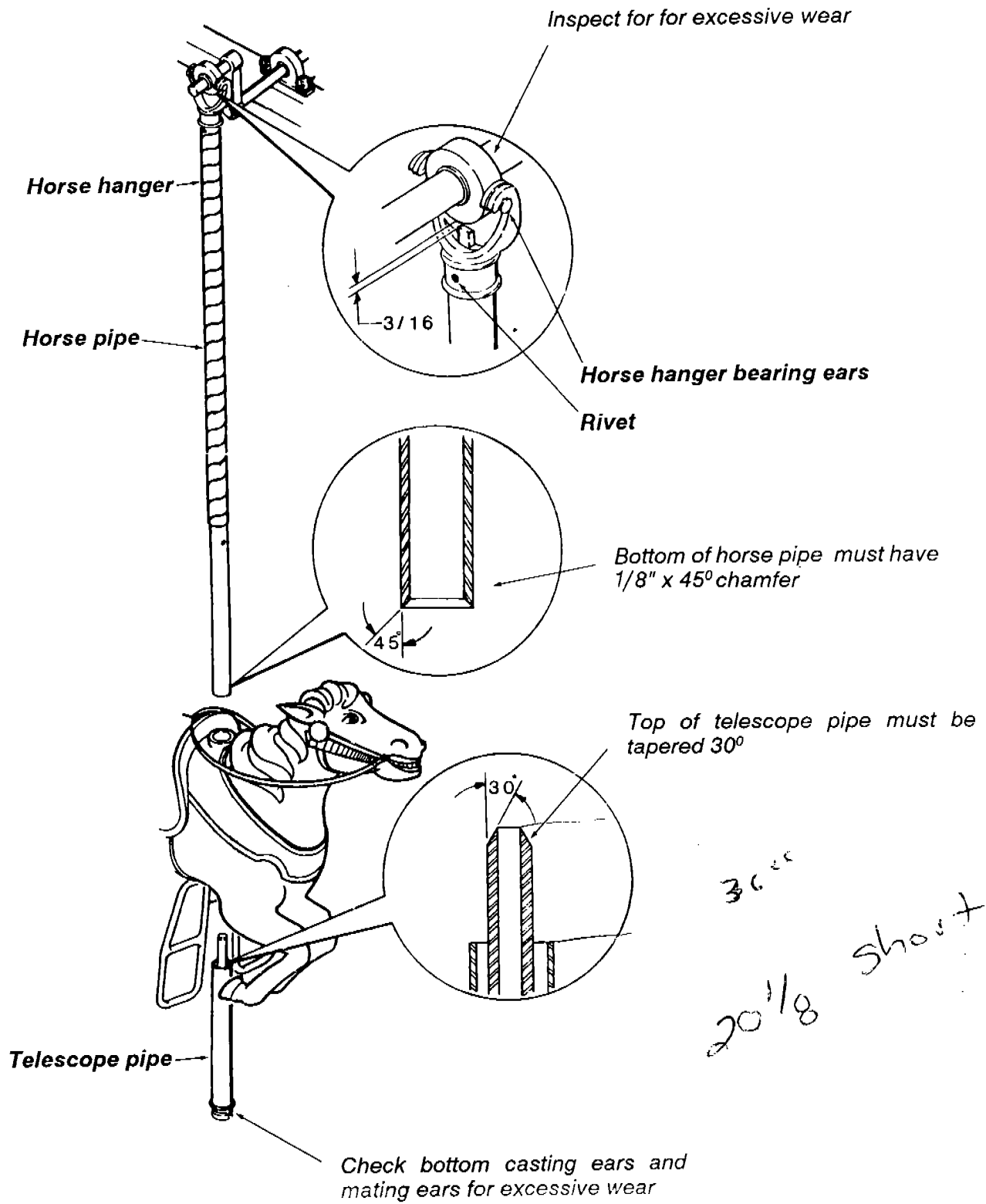

30°
20 1/8 Short

Sweep inspection

1. Inspect sweep attach points for signs of wear.

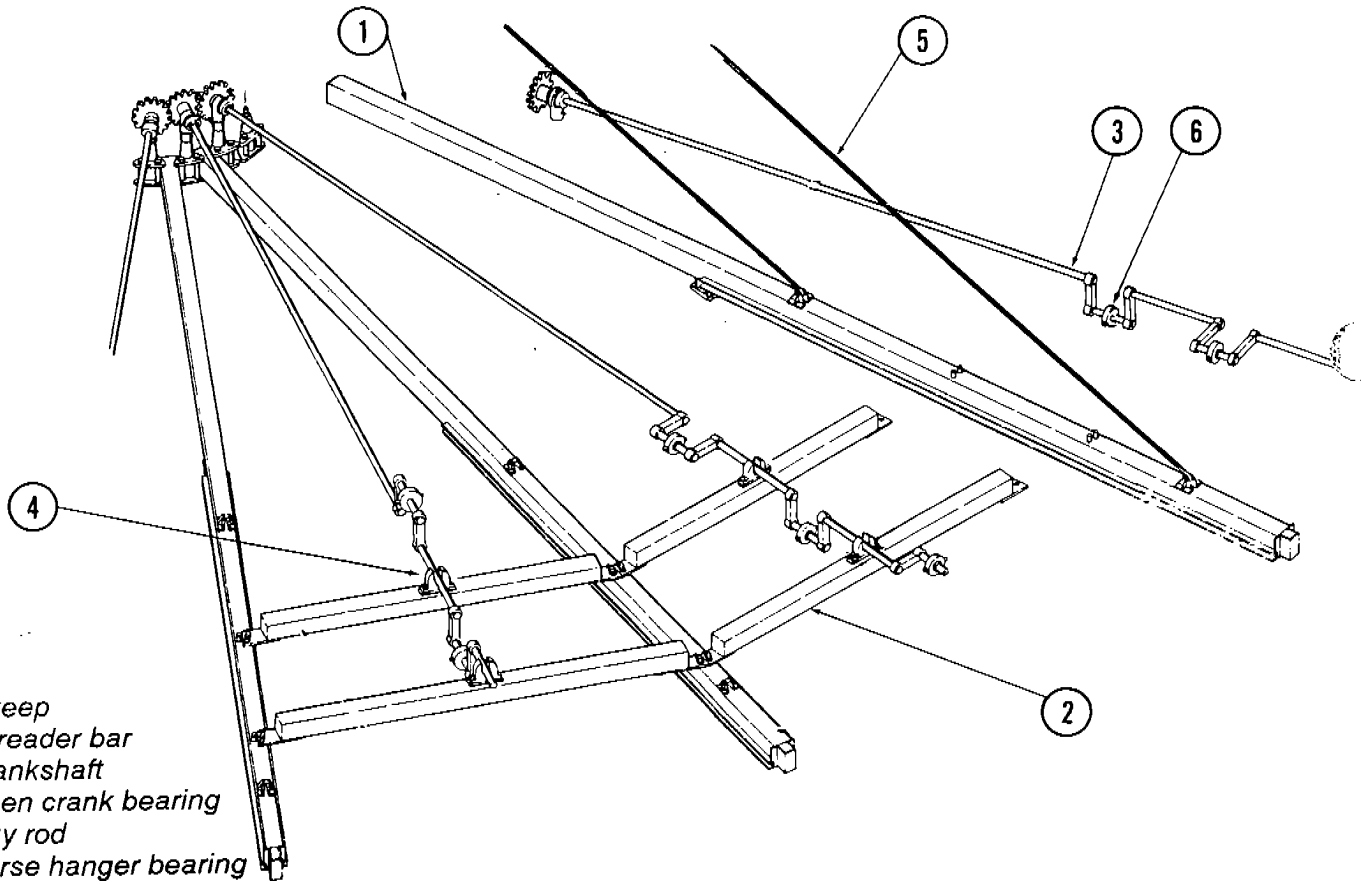

2. Inspect the installation of the spreader bars.

3. Inspect the installation of the guy rods.

4. Inspect open crank bearings and horse hanger bearings for wear and smooth operation.

5. Inspect sweeps, spreader bars and crankshafts for visible cracks or damage.

Electrical and lighting inspection

1. Inspect cable leads, electrical connections and grounding per local code.
2. Test the operator controls.

Trailer or park base inspection

1. Inspect center pole braces for installation of pins and hairpins.
2. Inspect mud sills (park model) for proper installation and foundation bolts, where applicable.
3. Inspect trailer or park base structures for visible cracks or damage.

Drive inspection

1. Inspect the drive chain and sprockets for alignment and proper tension. Check for 5/8" of chain deflection on the slack side of the chain.

Drive chain and sprockets

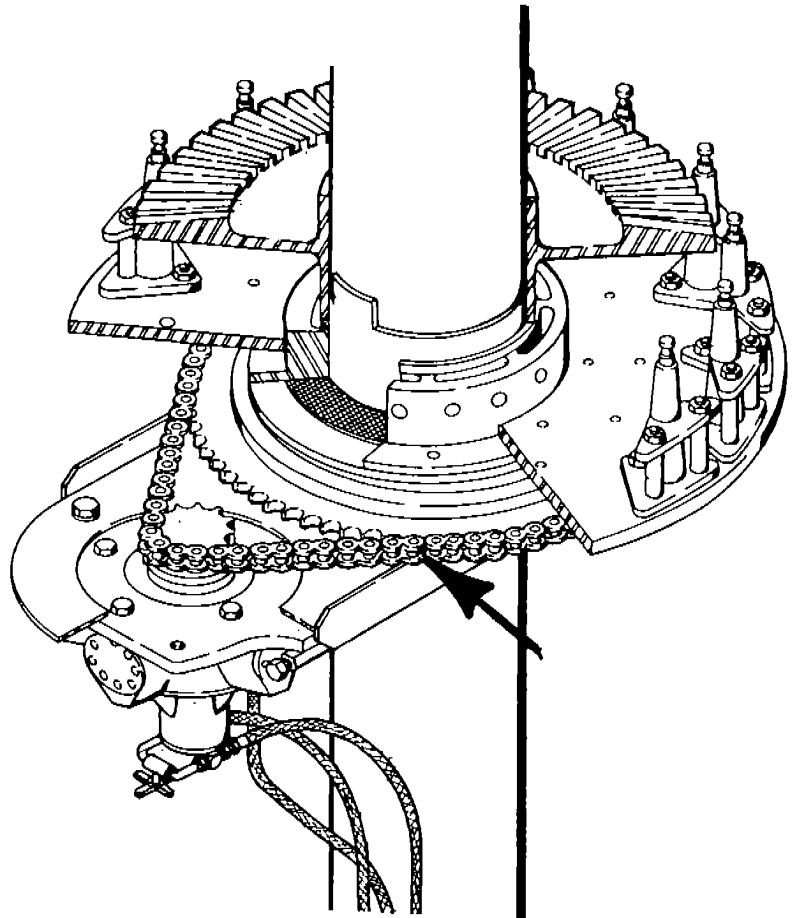

2. On rides with electric drive, check the drive belts and sheaves for alignment and proper tension. Check belt for 1/2" of deflection at 10 lbs pressure in the center of the top span.

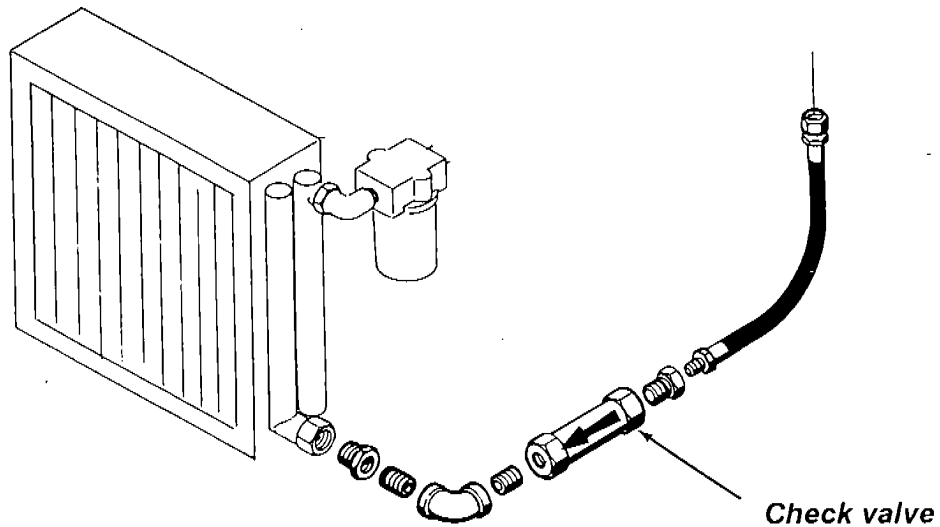

3. On rides with electro-hydraulic drive, inspect the entire hydraulic system including hoses, tubes, fittings and other components for leaks.

4. On 50 foot carrouseles, check for installation of the check valve as shown⁷.

Platform and fence inspection

1. Check platform heights as follows:
36 foot carrouseles $13" \pm 1"$
50 foot carrouseles $14" \pm 1"$
2. Check for installation of sway rods.

1. Sway rod
2. Floor hanger
3. Sweep
4. Floor

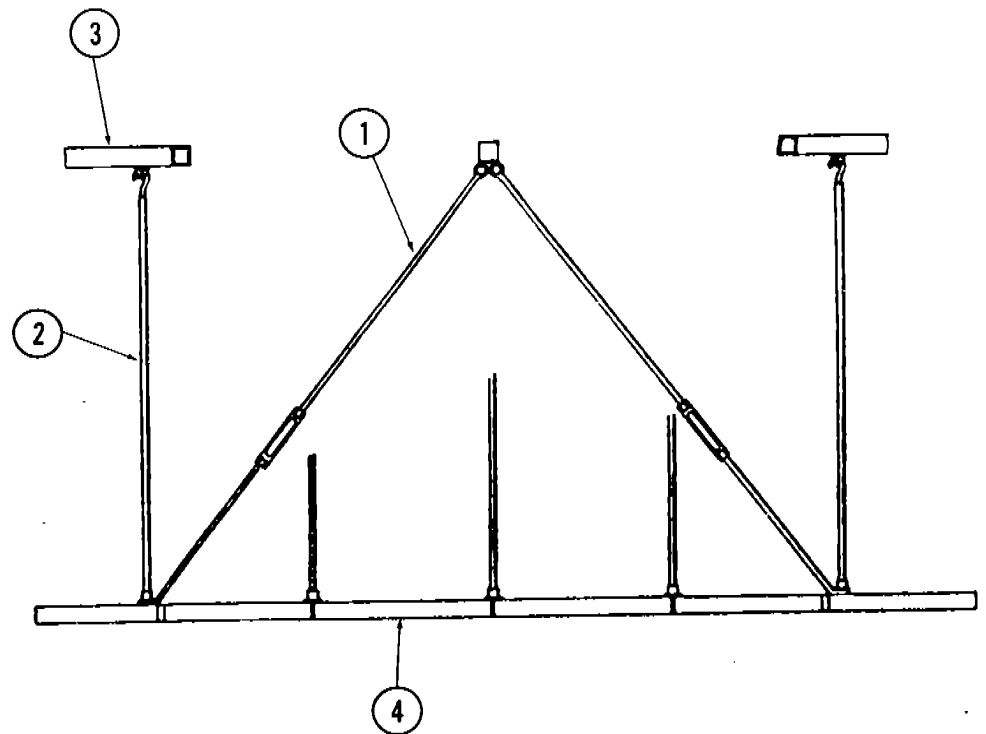

3. Check for proper adjustment of sway rods by measuring distance from ends of mud sill to the inside of the platform.

NOTE: On trailer mounted rides, measure from the centerline of the center pole to the inside of the platform

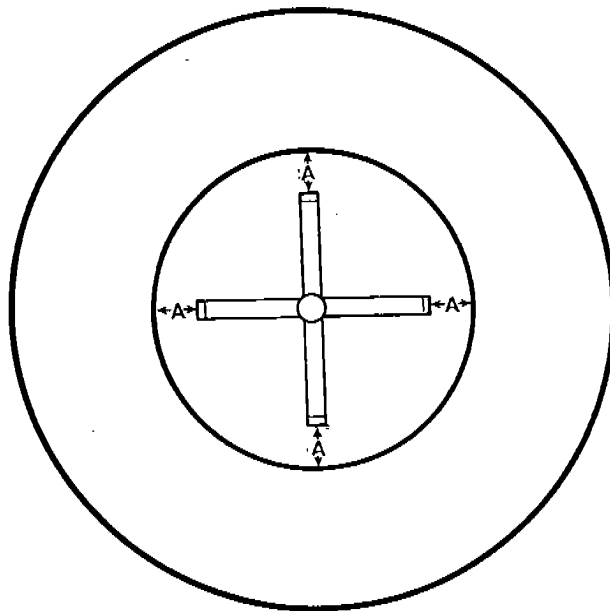

Dimension "A" must be equal at all places.

4. Inspect the fences for proper installation.

Bibliography

The following service bulletins and manuals are referenced in the preceding text. Service bulletins issued after publication of this guide are located at the back of each section. Any future bulletin releases affecting a ride will be provided by CHANCE RIDES, INC. Bulletins received after receipt of this guide should be considered updates to this guide.

CHANCE RIDES, INC.
4219 Irving
P.O. Box 12328
Wichita, KS 67277-2328

36-Foot Carrousel Operation And Maintenance Manual
24328200
June, 1987

50-Foot Carrousel Operation And Maintenance Manual
24327200
May, 1987

1. *Field Performance Testing Of Amusement Rides*
B090R1002-0
May 14, 1986
2. *Non-destructive Testing*
B090R1022-0
March 21, 1988
3. *General Safety - Taper Pins*
B090R1056-0
February 9, 1990
4. *Inspection Of Horse Hanger Hooks, Bearings,
Horse Pipe, And Telescope Assemblies*
B389R1068-0
May 22, 1990

5. *Cable Inspection*

B090R1071-0

May 25, 1990

6. *Replacement And Torque Requirements
For Functional Load Carrying Capscrews*

B090R1075-0

May 25, 1990

7. *Hydraulic Motor Cavitation*

B389R1085-0

November 30, 1990